

valid for 380 V - 415 V / 50 Hz

load capacity	1000 kg	flange width	126 mm - 200 mm
FEM group	2m / M5	lifting speed	1 / 4 m/min
number of falls	2	travelling speed	5 / 20 m/min
hook path	4000 mm		

drives

	hoist motor	travel drive
performance	0.22 / 0.9 kW	0.06 / 0.25 kW
duty cycle	60 %	50 %
no. of switching operations	360 c/h	240 c/h
nominal speed	640 / 2,700 1/min	600 / 2,800 1/min
rated current	1.5 / 2.1 A	0.44 / 0.93 A
starting current	2.8 / 11.5 A	0.79 / 4.5 A
cos phi _N	0.7 / 0.8	0.6 / 0.7
cos phi _A	0.85 / 0.9	0.75 / 0.9

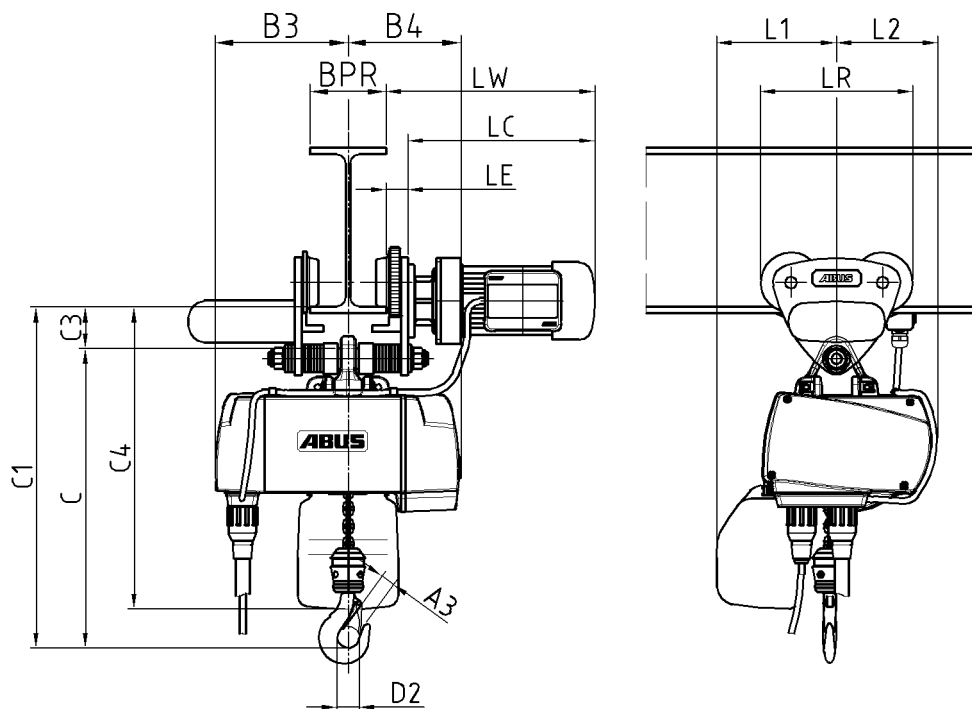

dimensions and weights

A3	31 mm	B3	217 mm	B4	185 mm	C	476 mm
C1	544 mm	C3	68 mm	C4	595 mm	D2	43 mm
L1	197 mm	L2	156 mm	LC	355 mm	LE	34 mm
LR	265 mm	LW	389 mm				
load hook	E 05 - V		weight	ca. 77 kg			

BPR _{min}	BPR _{max}	radius of curves
126 mm	140 mm	>= 1700 mm
141 mm	200 mm	>= 2100 mm

load data for the track according to DIN 4132

load case H		load case HZ	
R _{max} ¹⁾ / wheel	RKA _{min} ²⁾ / wheel	FSKA ³⁾ / hoist	FMKA ⁴⁾ / hoist
2642 N	189 N	528 N	113 N

¹⁾ Wheel load without coefficient

²⁾ Wheel load under dead weight without coefficient

³⁾ Loads transverse to the runway (hoist)

⁴⁾ Loads along the runway (hoist)

ABUS Kransysteme GmbH
Sonnenweg 1
51647 Gummersbach

monorail trolley with chain hoist
GM 4 1000.4-2/EF 14

18/08/2015